

# Product Safety Recall

## AEG, Electrolux, Electrolux Dishlex and Westinghouse dishwashers

### Models affected:-

AEG	- F40760, F44080IM
Electrolux	- EX401ISB, ESL6163
Electrolux Dishlex	- DX303SK, DX303WK
Westinghouse	- SB908WK, SB908SK, SB916WK, SB916SK, SB926WK, SB926SK

Serial number range: 70700000 to 72400000, or any serial number prefixed with A, B or C sold after April 2007

If you have any of the above models and if you have not received a call or contacted Electrolux already, contact the Call Centre on **1800 001 218** or email Electrolux at [customercare@electrolux.com.au](mailto:customercare@electrolux.com.au) to determine if your machine is affected.

**WARNING: If you own one of the above dishwashers, do NOT operate it before it has been attended to by an authorised Electrolux service technician**

### What is the fault?

A wire connector within the appliance may, in extreme cases, overheat and cause a fire or melting of plastic components within the control panel. **There is also a risk that the fire could spread outside the appliance.**

The model and serial numbers are easily discernible on the front right side of the inner door panel (see diagram).

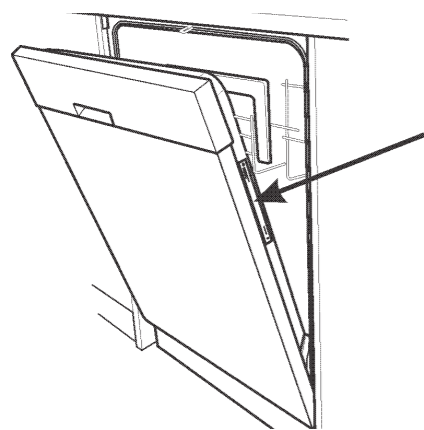

If you own one of these dishwashers, irrespective of whether you have responded to previous recall notices and your dishwasher was serviced, please have the model and serial number ready and call the toll free number **1800 001 218** to register your details during the following hours:-

**Monday to Friday: 8am and 7pm EST**  
**Weekends 10am and 3pm EST**

Electrolux will make arrangements for a service technician to call and check your appliance free of charge. If your dishwasher is affected, do not operate it until it has been checked. **This applies to all the above dishwasher models.**

## Frequently asked questions

### I have never had a service call, what should I do?

Please ring 1800 001 218 to arrange an inspection free of charge.

### I have a “second” quality dishwasher, what should I do?

If you have a second quality dishwasher (which can be identified by a serial number with a prefix of A, B or C) and it was purchased after April 2007 and you have never had a service call or contacted us, please ring 1800 001 218 to arrange an inspection free of charge.

### How do I know if the correct repair method has been used on my dishwasher?

If you have had a service call on your dishwasher, a green 38mm diameter round sticker with the word “INSPECTED” will be found in the same location that the serial number can be read. See image on the right. If you do not have this sticker, your dishwasher may need to be re-inspected. Please ring 1800 001 218.



### I'm still worried, what should I do?

If you have any other doubts or concerns, please contact us on 1800 001 218.

Electrolux Home Products Pty Limited ABN 51 004 762 341  
163 O’Riordan Street, Mascot NSW 2020



See [www.recalls.gov.au](http://www.recalls.gov.au) for Australian Product Recall Information